

UNI KLINGER BELLOW SEAL VALVES:-

It has been proven through various studies about process plant emission that 75% of leakages cause :

- *Environmental Pollution*
- *Production loss*
- *Process Problems*
- *Energy Loss*

In line with present emphasis on prevention of environmental pollution and energy saving it is necessary to arrest completely.

UKL Bellow Seal Valves save energy, arrest leakages and prevent environmental pollution.

Irrespective of proper selection, installation, periodic and preventive care on conventional valves, leakages cannot be totally eliminated. Through performance seems

Selection of Bellow seal valves is the only solution for this problem. Therefore the use of Bellow seal Valve is on increase.

UKL Bellow seal valves are designed and manufactured as per international standards, such as ANSI, API, ASTM, BS, DIN, MSS, etc.

Custom made valves are designed based on feed back from actual users and understanding the customer specific requirements.

UKL Bellow Seal Valves are highly recommended for:-

Santotherm-66, Dowtherm, Hot Oil/HTM, Vaccum, Steam, ammonia, Refrigerant, Phosgene, Chlorine, Hydrogen, Oxygen, CO, Hazardous and Poisonous liquids, gases and radio active substances, etc.



Bellow Seal Valves

UBSV

BELLOW SEAL GLOBE VALVE

MODEL : UBGB-FT02

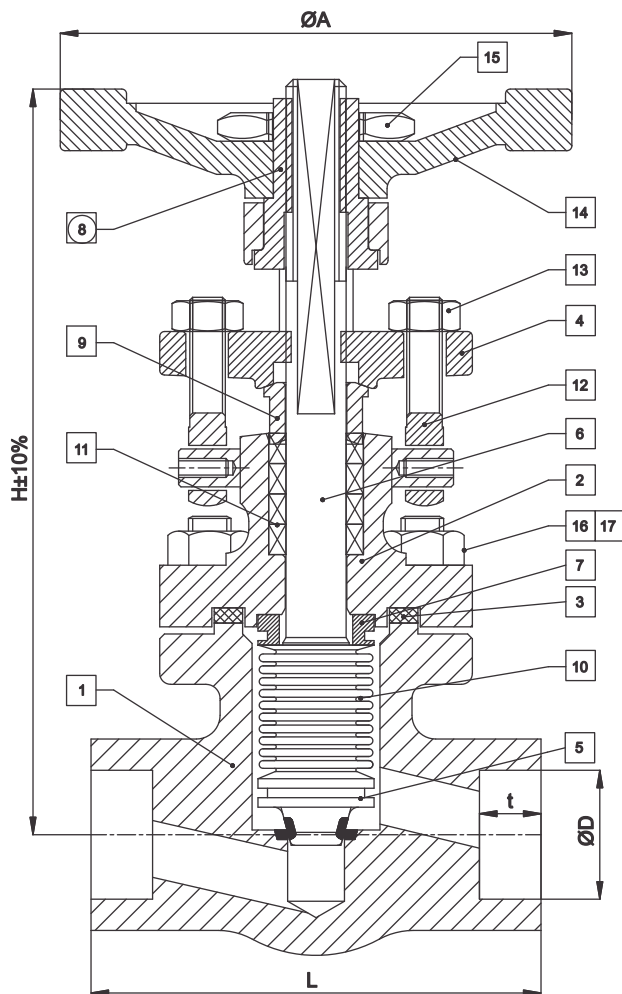

BILL OF MATERIAL

NO. PART	PART NAME	MATERIAL CODE
1	BODY	ASTM A105
2	BONNET	ASTM A105
3	BODY GASKET	SPW 304+GRAPHITE FILLER
4	GLAND FLANGE	ASTM A105
5	PLUG	ASTM A276 TP.410 + ST.
6	STEM	ASTM A276 TP.410
7	TOP BELLOW COLLAR	ASTM A276 TP.316
8	YOKE SLEEVE	SG IRON
9	GLAND BUSH	ASTM A276 TP.410
10	BELLOW	AISI 316 Ti
11	GLAND PACKING	GRAPHITE
12	EYE BOLT	ASTM A 193 Gr.B7
13	EYE BOLT NUT	ASTM A 194 Gr.2H
14	HAND WHEEL	CAST IRON / CS
15	HAND WHEEL NUT	CARBON STEEL
16	STUD	ASTM A 193 Gr.B7
17	NUT	ASTM A 194 Gr.2H

Limiting Conditions:

Test Pressure	#150	#300	#600	#800
Body (Hydro)	30 kg/cm ²	79 kg/cm ²	157 kg/cm ²	209 kg/cm ²
Seat (Hydro)	22 kg/cm ²	58 kg/cm ²	115 kg/cm ²	153 kg/cm ²
Seat (Pne.)	07 kg/cm ²	07 kg/cm ²	07 kg/cm ²	07 kg/cm ²

Dimensions (mm) :

Size (NB)	15	20	25	40	50
Overall Length (L)	85	90	106	127	140
Height (H)	150	162	167	237	242
H.W. Dia (ØA)	108	108	108	172	172
Socket Weld Dia (ØD)	21.8	27.2	33.9	48.8	61.2
Socket Depth (t)	10	13	13	13	16

Bellow Seal Valves

UBSV

BELLOW SEAL GLOBE VALVE

MODEL : UBGB-CT02

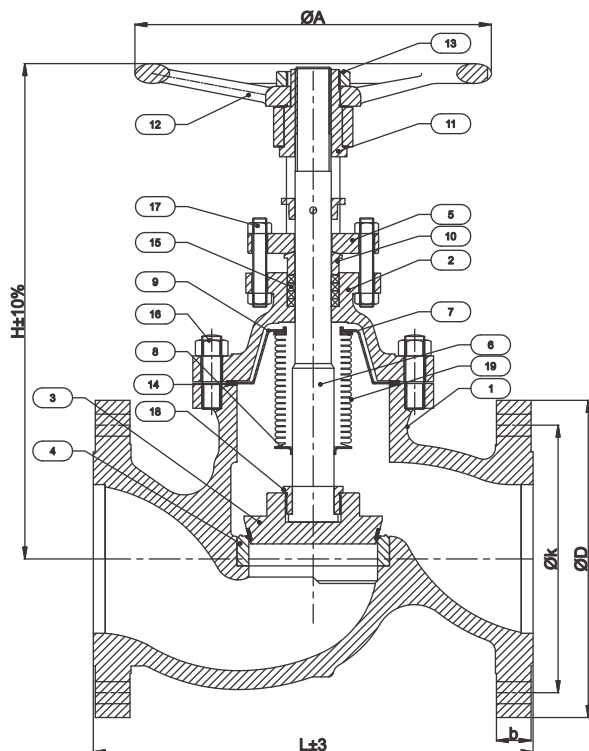

BILL OF MATERIAL :

Sr. No.	PART DESCRIPTION	M.O.C.
1	BODY	ASTM A 216 GR. WCB
2	BONNET	ASTM A 216 GR. WCB
3	PLUG	ASTM A 276 TP 410 / WCB + ST.
4	SEAT	ASTM A 276 TP 410 / WCB + ST.
5	GLAND FLANGE	A 105 / ASTM A 216 Gr. WCB
6	STEM	ASTM A 276 TP 410
7	TOP BELLOW COLLAR	ASTM A 276 TP 316
8	BOTTOM BELLOW COLLAR	ASTM A 276 TP 316
9	BELLOW CAP	SS 316
10	GLAND BUSH	ASTM A 276 TP 410
11	YOKE SLEEVE	S. G. IRON
12	HAND WHEEL	CARBON STEEL
13	HAND WHEEL NUT	CARBON STEEL
14	BODY BONNET GASKET	GRAPHITE
15	GLAND PACKING	GRAPHITE
16	BODY - BONNET STUD-NUT	ASTM A 193 GR. B7 / ASTM A 194 GR. 2H
17	GLAND FLANGE STUD-NUT	ASTM A 193 GR. B7 / ASTM A 194 GR. 2H
18	STEM NUT	ASTM A 276 TP 410
19	BELLOW	SS 316Ti

Limiting Conditions :

Test Pressure	#150	#300
Body (Hydro)	30 kg/cm ²	79 kg/cm ²
Seat (Hydro)	22 kg/cm ²	58 kg/cm ²
Seat (Pne.)	07 kg/cm ²	07 kg/cm ²

CLASS : 150									
SIZE (NB)	25	40	50	65	80	100	125	150	200
Overall Length (L)	127	165	203	216	241	292	356	406	495
Height (H±10%)	225	270	280	310	375	405	490	510	570
H.W. Dia. (ØA)	150	205	254	254	305	356	460	460	559
Flange Dia(ØD)	110	125	150	180	190	230	255	280	345
Flange thk. (b)	12.7	15.9	17.5	20.7	22.3	22.3	22.3	23.9	27
Flange P.C.D (Øk)	79.4	98.4	120.7	139.7	152.4	190.5	215.9	241.3	298.5

CLASS : 300									
SIZE (NB)	25	40	50	65	80	100	125	150	200
Overall Length (L)	203	229	267	292	318	356	400	444	559
Height (H±10%)	225	270	290	310	375	405	490	510	570
H.W. Dia. (ØA)	150	205	254	254	305	356	460	460	559
Flange Dia(ØD)	125	155	165	190	210	255	280	320	380
Flange thk. (b)	15.9	19.1	20.7	23.9	27	30.2	33.4	35	39.7
Flange P.C.D (Øk)	88.9	114.3	127	149.2	168.3	200	235	269.9	330.2



UNI KLINGER LIMITED - AN ISO 9001 : 2015 COMPANY

Bellow Seal Valves

UBSV

BELLOW SEAL GLOBE VALVE

MODEL : UBGB-FT02

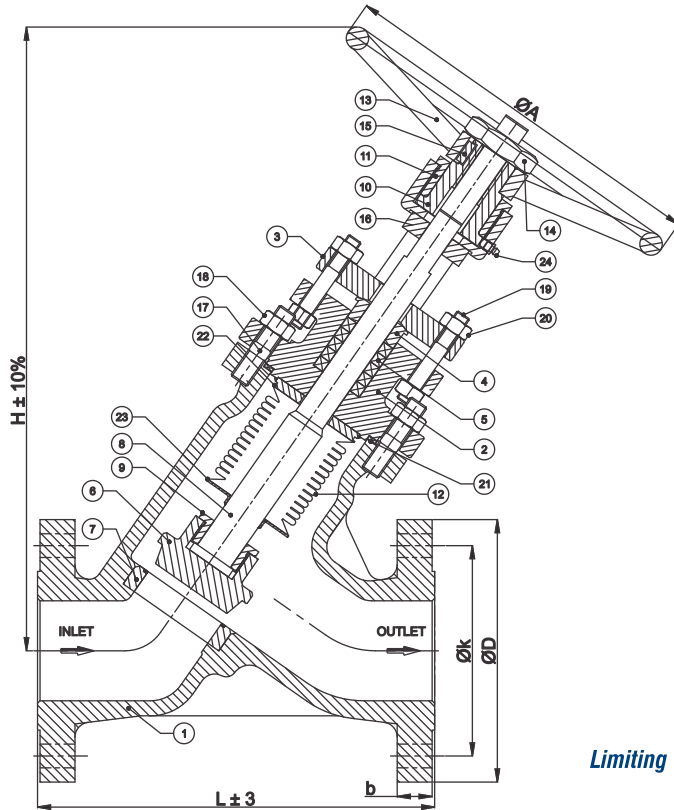

BILL OF MATERIAL :

SR. NO.	PART NAME	M.O.C.
1	BODY	ASTM A 216 GR. WCB
2	BONNET	ASTM A 216 GR. WCB
3	GLAND FLANGE	ASTM A 105
4	GLAND BUSH	ASTM A276 TP 410
5	GLAND PACKING	GRAPHITE
6	PLUG	ASTM A 216 GR. WCB / AISI 410+ST
7	SEAT	ASTM A 216 GR. WCB / AISI 410+ST
8	STEM	ASTM A 276 TP 410
9	STEM NUT	ASTM A276 TP 410
10	YOKE SLEEVE	S.G. IRON
11	YOKE NUT	IS 2062 Gr.B
12	BELLOW	AISI 316 Ti
13	HAND WHEEL	CARBON STEEL
14	HAND WHEEL NUT	CARBON STEEL
15	HAND WHEEL KEY	CARBON STEEL
16	GUIDE PLATE	CARBON STEEL
17	STUD	ASTM A 193 GR. B7
18	NUT	ASTM A 194 GR. 2H
19	STUD / EYE BOLTS	ASTM A 193 GR. B7
20	NUT	ASTM A 194 GR. 2H
21	BODY GASKET	SPW AISI 304 WITH GRAPHITE FILLER
22	TOP BELLOW COLLAR	ASTM A 276 TP 316
23	BOTTOM BELLOW COLLAR	ASTM A 276 TP 316
24	GREASE NIPPLE	CARBON STEEL

Limiting Conditions :

Test Pressure	#150	#300
Body (Hydro)	30 kg/cm ²	79 kg/cm ²
Seat (Hydro)	22 kg/cm ²	58 kg/cm ²
Seat (Pne.)	07 kg/cm ²	07 kg/cm ²

CLASS : 150

Size (DN) NB	50	65	80	100	125	150	200	250	300
Overall Length (L)	229	279	318	368	400	470	597	694	810
Height (H \pm 10 %)	380	425	510	555	635	700	845	960	1105
H.W. Dia. (ØA)	254	254	305	356	460	460	559	610	610
Flange Dia (ØD)	150	180	190	230	255	280	345	405	485
Flange Thk (b)	17.5	20.7	22.3	22.3	22.3	23.9	27	29	30.2
Flange PCD (Øk)	121	140	152	191	216	241	299	362	432

CLASS : 300

Size (ØDN) NB	50	65	80	100	125	150	200	250	300
Overall Length (L)	267	292	318	356	400	444	559	730	850
Height (H \pm 10 %)	380	425	510	555	635	700	845	960	1105
H.W. Dia. (ØA)	254	254	305	356	460	460	559	610	610
Flange Dia (ØD)	165	190	210	255	280	320	380	445	520
Flange Thk (b)	20.7	23.9	27	30.2	33.4	35	39.7	46	49.3
Flange PCD (Øk)	127	149	168	200	235	270	330	387	451

Bellow Seal Valves

UBSV

BELLOW SEAL GLOBE VALVE

MODEL : UBGB-CT02

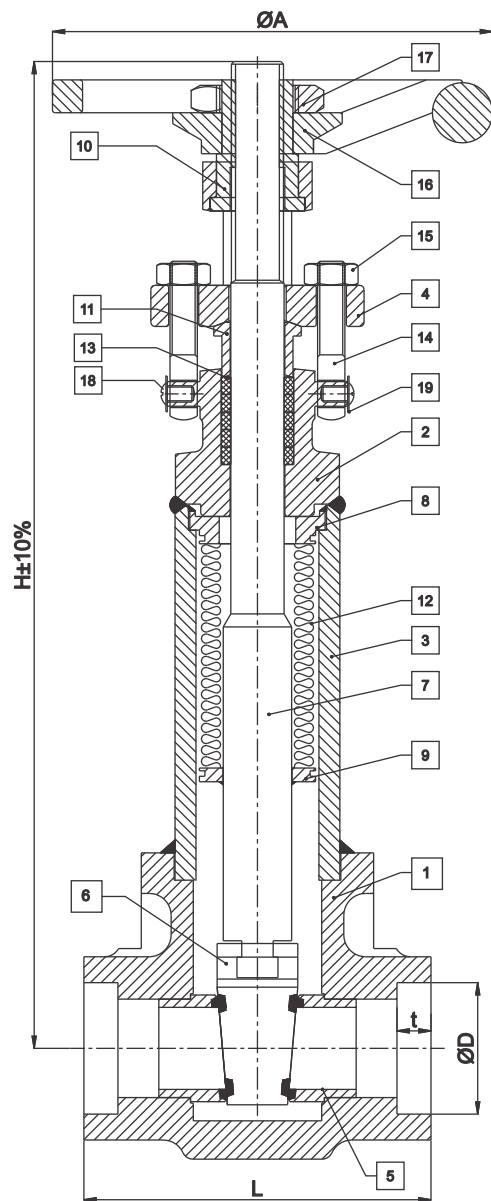

PART NO.	PART NAME	M.O.C.
1	BODY	ASTM A 105
2	BONNET	ASTM A 105
3	CYLINDER PIPE	ASTM A 106 Gr.B
4	GLAND FLANGE	ASTM A 105
5	SEAT	ASTM A 276 TP 410+ STELLITE
6	WEDGE	ASTM A 276 TP 410+ STELLITE
7	STEM	ASTM A 276 TP 410
8	TOP BELLOW COLLAR	ASTM A 276 TP 316
9	BOTTOM BELLOW COLLAR	ASTM A 276 TP 316
10	YOKE SLEEVE	S. G. IRON
11	GLAND BUSH	ASTM A 276 TP 410
12	BELLOW	AISI 316 Ti
13	GLAND PACKING	GRAPHITE
14	EYE BOLT	ASTM A 193 Gr.B7
15	EYE BOLT NUT	ASTM A 194 Gr.2H
16	HAND WHEEL	CAST IRON
17	HAND WHEEL NUT	CARBON STEEL
18	SCREW	CARBON STEEL
19	WASHER	CARBON STEEL

Limiting Conditions:

Test Pressure	#150	#300	#600	#800
Body (Hydro)	30 kg/cm ²	79 kg/cm ²	157 kg/cm ²	209 kg/cm ²
Seat (Hydro)	22 kg/cm ²	58 kg/cm ²	115 kg/cm ²	153 kg/cm ²
Seat (Pne.)	07 kg/cm ²	07 kg/cm ²	07 kg/cm ²	07 kg/cm ²

Dimensions (mm)					
Size (Ø DN) NB	15	20	25	40	50
Overall Length (L)	86	94	107	127	140
Height (H)	252	283	303	386	512
H.W Dia (Ø A)	108	108	108	172	172
Socket Weld Dia (Ø D)	21.8	27.2	33.9	48.8	61.2
Socket Depth (t)	10	13	13	13	16

Bellow Seal Valves

UBSV

BELLOW SEAL GLOBE VALVE

MODEL : UBGB-FT02

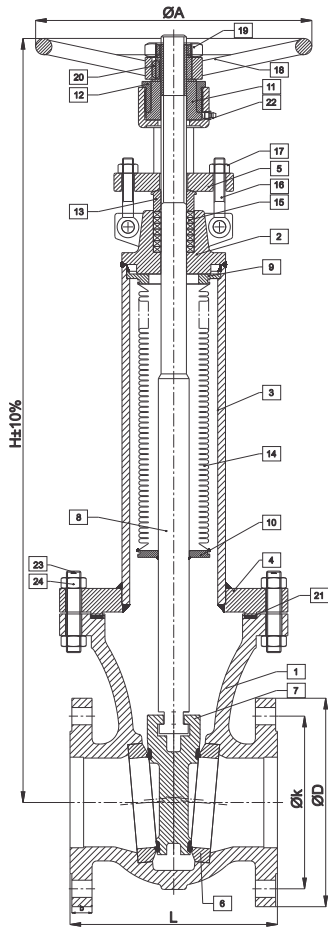

Limiting Conditions:

Test Pressure	#150	#300
Body (Hydro)	30 kg/cm ²	79 kg/cm ²
Seat (Hydro)	22 kg/cm ²	58 kg/cm ²
Seat (Pne.)	07 kg/cm ²	07 kg/cm ²

PART NO.	PART NAME	M.O.C
1	BODY	ASTM A 216 GR. WCB
2	BONNET	ASTM A 216 GR. WCB
3	CYLINDER PIPE	ASTM A 106 GR.B.
4*	CYLINDER FLANGE *	ASTM A 216 GR. WCB / ASTM A 105
5	GLAND FLANGE	ASTM A 216 GR. WCB / ASTM A 105
6	SEAT	ASTM A 216 GR. WCB +ST Gr.6
7	WEDGE	ASTM A 216 GR. WCB +ST Gr.6
8	STEM	ASTM A 276 TP 410
9	TOP BELLOW COLLAR	ASTM A 276 TP 316
10	BOTTOM BELLOW COLLAR	ASTM A 276 TP 316
11	YOKE SLEEVE	S.G. IRON
12	YOKE NUT	ASTM A276 TP 410
13	GLAND BUSH	ASTM A276 TP 410
14	BELLOW	AISI 316 Ti
15	GLAND PACKING	GRAPHITE
16	EYE BOLT	ASTM A 193 GR. B7
17	EYE BOLT NUT	ASTM A 194 GR. 2H
18	HAND WHEEL	CARBON STEEL
19	HAND WHEEL NUT	CARBON STEEL
20	HAND WHEEL KEY	IS 2062 Gr.B
21	BODY GASKET	SPW 304+ GRAPHITE FILLER
22	GREASE NIPPLE	IS 2062 Gr.B
23	STUD	ASTM A 193 GR. B7
24	STUD NUT	ASTM A 194 GR. 2H

CLASS:150

Size (NB)	50	65	80	100	150	200	250	300
Overall Length(L)	178	190	203	229	267	292	330	356
Height (H ±10%)	482	490	710	847	1125	1480	1715	1820
H. W Dia (Ø A)	254	254	305	305	460	559	610	711
Flange Dia (ØD)	150	180	190	230	280	345	405	485
Flange thk (b)	17.5	20.7	22.3	22.3	23.9	27	28.6	30.2
Flange PCD(Øk)	121	140	152	191	241	299	362	432

CLASS:300

Size (NB)	50	65	80	100	150	200	250	300
Overall Length(L)	216	241	282	305	403	419	457	502
Height(H ±10%)	495	510	710	847	1125	1480	1715	1820
H. W Dia (Ø A)	254	254	305	305	460	559	610	711
Flange (ØD)	165	190	210	255	320	380	445	520
Flange thk (b)	20.7	23.9	27	30.2	35	39.7	46.1	49.3
Flange PCD(Øk)	127	149	168	200	270	330	387	451



Other Products : Cast / Forged Steel Piston Valves, Bellow seal valves, High Pressure valves (Gate/Globe), Strainers – “Y” Type, ITVS Steam Traps (Thermodynamic, Thermostatic, Ball Float Traps and IBT), Pressure Reducing Station, Condensate Recovery Products. Level Gauges (Reflex, Transparent, Bicolor), Sight Glass, Hot Water Generation System, Safety and Relief Valves.

FSD Products : Compressed Asbestos / Non Asbestos Fiber Sheetting / Cut Gaskets, Spiral Wound Gaskets / Gland Packing

In view of technical progress designs and dimensions are subject to change without notice.



UNI KLINGER LIMITED

A joint venture of the Neterwala group of companies and KLINGER AG, Switzerland.



HARSH ENGINEERING SALES & SERVICE PVT. LTD

Only Authorized Dealers for UNI KLINGER products, Telangana

Add: 2-3-692/22/13 Lal Bagh, Zinda Tilismath Road, Ganga Nagar, Amberpet, Hyderabad - 500013
Tel: +91-40-2740 3329 | Website: harsh-engineering.com | E-mail: sales@harsh-engineering.com