

UKL HIGH PRESSURE VALVE

- UKL High Pressure Gate and Globe Valves are manufactured to the latest International designs, using latest state of art technology and a strict quality control system.
- These valves are exceptionally sturdy, rugged and durable.
- They are designed for a tight seal, ease of operation with inbuilt Quality and integrity for a long service life.



Industrial Application

- Power Stations, General Industries, Chemical and Process Industries, Sugar, Refineries, Fertilizers, steel, Off-shore Platforms.
- For Water, Steam (saturated/ Superheated) Oil and Gas, Hydrocarbons, NACE and sour services, LNG and Natural Gas, Oxygen , Hydrogen and many other Process applications.
- All valves up to 50 mm are outside screw and yoke, Welded Bonnet Type Design, rising stem, renewable seat for Gate valves. Globe valves will have integral seat.
- Pressure Seal Bonnet Design valves are above and including 50 NB are also outside screw and yoke, rising stem.
- Gate valves shall be with Flexible wedge type Gate. Globe Valves shall have conical type disc.
- Stellite Hard faced seat and disc.
- Direct Retro-fitted Actuator / Gear Box arrangement as applicable.

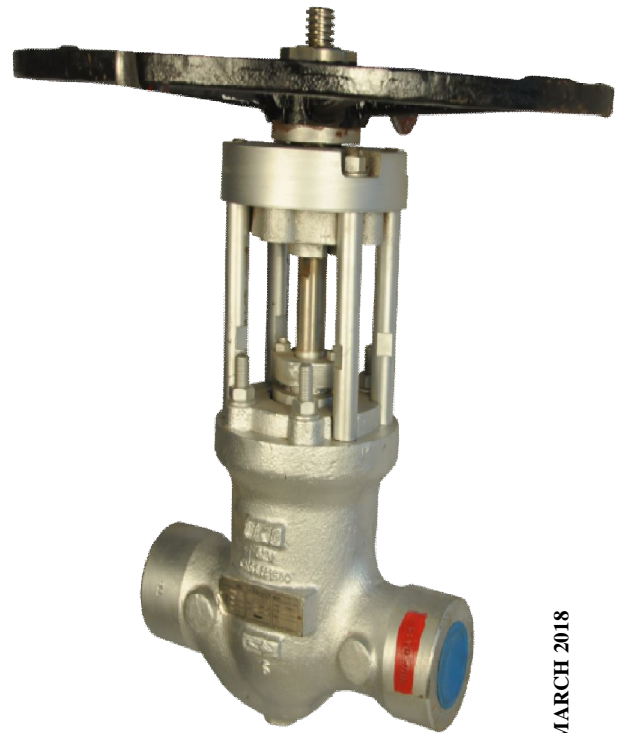

UKL-DS-UHPV-R00-MARCH 2018

Design Specification

UKL High Pressure Gate and Globe valves

Sizes: 15NB to 250 NB

Valves 15 to 50 NB are in forging.

Valves 50 to 250 NB are in casting.

RANGE:

15 NB to 50 NB - Forged steel, welded bonnet,
SW/BW Ends

50 NB to 250 NB - Cast steel & Alloys steel,
Butt weld Ends

Pressure –Temperature Rating:

As per ASME B 16.34 : Class 1500 & 2500

15 - 50NB Y-Type Globe Valve #1500 & #2500

15 - 250NB T-Type Globe Valve #1500 & #2500

15 - 250NB Gate valve #1500 & #2500

MATERIAL OF CONSTRUCTION:-

Carbon steel:- (0 °C to 425 °C)

ASTM A 105 / ASTM A 216 Gr. WCB

Alloy steel:- (0 °C to 593 °C)

ASTM A 182 Gr. F11/ F22

ASTM A 217 Gr. WC6/WC9

Other material on request.

OPTIONAL:-

By Pass Arrangement

Manual Gear Box (for 15 to 80 NB)

Electrical Actuator (for 15 to 250 NB)

Position Indicator

Locking Arrangement

COMMON INSPECTIONS/TESTS

Test/Inspection

Visual Inspection

Chemical Analysis

Mechanical Properties

Radiographic Insp.

Pressure Testing

Dimensional Insp.

Acceptance Criteria

MSS SP55

Relevant ASTM Std.

Relevant ASTM Std.

ASME B 16.34

API 598/ BS 6755

Valve Standard

- Other NDT Tests- On Request
- IBR Certification on Request

Every individual valve manufactured at UKL is inspected and pressure tested to API 598 / BS 6755 Part I requirements, for which test certificates are provided.

Compliance Standards

Parameter

Standard

1) Valve design

Gate Valve

ASME B 16.34

Globe Valve

ASME B 16.34 / API602

2) Face to Face

Manufacturer's Standard

3) Butt Weld End

ASME B 16.25

4) Socket Weld End

ASME B 16.11

5) Testing

API 598 / BS 6755

Operating Data

Parameter	ASTM A 105 / ASTM A 216 Gr. WCB		ASTM A 182 Gr. F11/F22 /ASTM A 217 Gr. C6/WC9	
	#1500	#2500	#1500	#2500
Max. Working Pressure [Kg/cm ²]	260.33	433.90	263.40	439.40
Max. Working Temperature [°C]	425.00	425.00	595.00	595.00
Shell Hydro Test Pressure [Kg/cm ²]	391.00	651.00	396.00	660.00
Seat Hydro Test Pressure [Kg/cm ²]	1.1 Times Operating Pressure			
Seat Pneumatic Test Pressure [Kg/cm ²]	7.00	7.00	7.00	7.00



Model: UHPGTV with Hand Wheel (Standard Product)

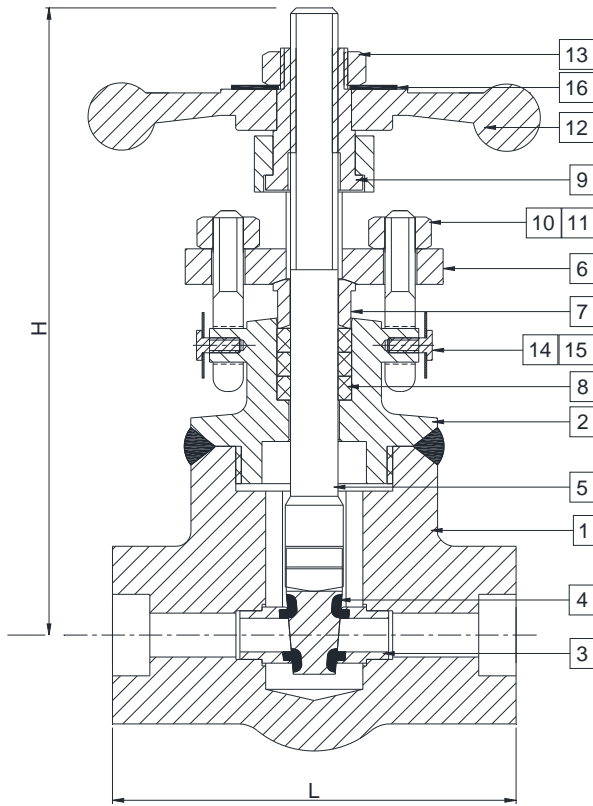

Sr.	Size	Class	L	H
1	15	1500	108.00	168.00
2	20	1500	108.00	170.00
3	25	1500	142.00	225.00
4	40	1500	209.00	284.00
5	50	1500	209.00	283.00

Sr.	Size	Class	L	H
1	15	2500	102.00	260.00
2	20	2500	144.00	280.00
3	25	2500	144.00	280.00
4	40	2500	209.00	359.00
5	50	2500	209.00	354.00

No.	PART NAME	MATERIAL	MATERIAL CODE
1	Body	Forged Steel	ASTM A105 /A182F11/F22
2	Bonnet	Forged Steel	ASTM A105 /A182F11/F22
3	Seat	Stainless Steel + St.	ASTM A276 -TP410
4	Wedge	Stainless Steel	ASTM A276 -TP410
5	Stem	Stainless Steel	ASTM A276-TP410 / AISI 431
6	Gland Flange	Forged Steel	ASTM A105 /A182F11/F22
7	Gland Bush	Klinger Std.	ASTM A276-TP410
8	Gland Packing	Graphite	Embedded-Die Formed Graphite
9	Yoke Sleeve	SG Iron 400/12	SG Iron 400/12
10	Eye Bolt / Stud	Alloy Steel	ASTM A 193 Gr.B7 / B16
11	Nut	Carbon Steel	ASTM A 194 Gr.2H/Gr. 4 / Gr. 7
12	Hand Wheel	M.I./C.S.	M.I./C.S.
13	Hand Wheel Nut	Carbon Steel	ASTM A 194 Gr.2H
14	Cheese Head Screw	Carbon Steel	Carbon Steel
15	Washer	Carbon Steel	Carbon Steel
16	Name Plate	Stainless Steel	Stainless Steel

Note: Electrical Actuator can be provided on request.

Model: UHPGLV with Hand Wheel (Standard Product)

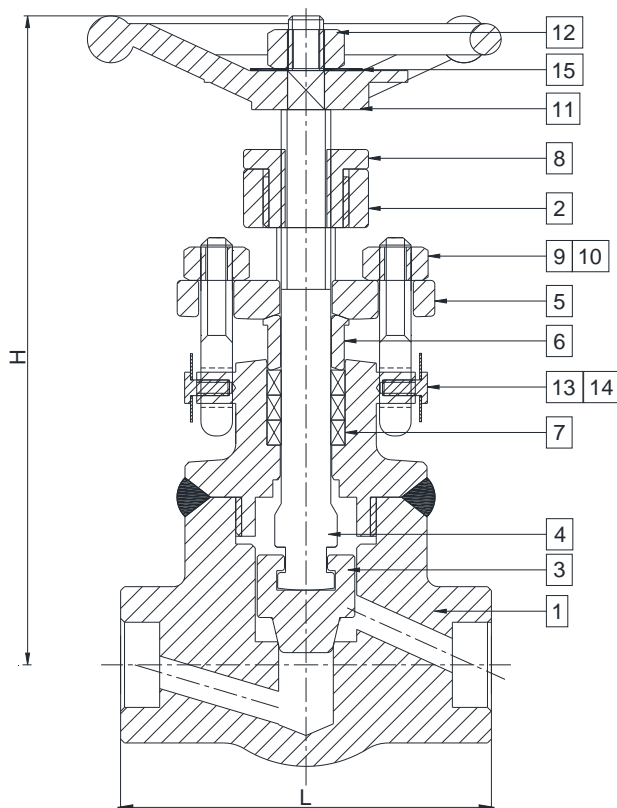

Sr.	Size	Class	L	H
1	15	1500	95.00	166.00
2	20	1500	122.00	226.00
3	25	1500	135.00	233.00
4	40	1500	209.00	280.00
5	50	1500	209.00	280.00

Sr.	Size	Class	L	H
1	15	2500	102.00	263.00
2	20	2500	122.00	288.00
3	25	2500	135.00	290.00
4	40	2500	209.00	370.00
5	50	2500	209.00	370.00

No.	PART NAME	MATERIAL	MATERIAL CODE
1	Body	Forged Steel	ASTM A105 /A182F11/F22
2	Bonnet	Forged Steel	ASTM A105 /A182F11/F22
3	Plug	S.S. + St.	ASTM A276-TP 410
4	Stem	Stainless Steel	ASTM A276 / A479-TP 410 / AISI 431
5	Gland Flange	Forged Steel	ASTM A105/A182F11/F22
6	Gland Bush	Klinger Std.	ASTM A276-TP410
7	Gland Packing	Graphite	Embedded -Die Formed Graphite
8	Yoke Nut	SG Iron 400/12	SG Iron 400/12
9	Eye Bolt / Stud	Alloy Steel	ASTM A 193 Gr.B7 / B16
10	Nut	Carbon Steel	ASTM A 194 Gr.2H/Gr. 4 / Gr. 7
11	Hand Wheel	M.I./C.S.	M.I./C.S.
12	Hand Wheel Nut	Carbon Steel	ASTM A 194 Gr.2H
13	Cheese Head Screw	Carbon Steel	Carbon Steel
14	Washer	Carbon Steel	Carbon Steel
15	Name Plate	Stainless Steel	Stainless Steel

Note: Electrical Actuator can be provided on request.



Model: UHPGLV-Y with Hand Wheel (Standard Product)

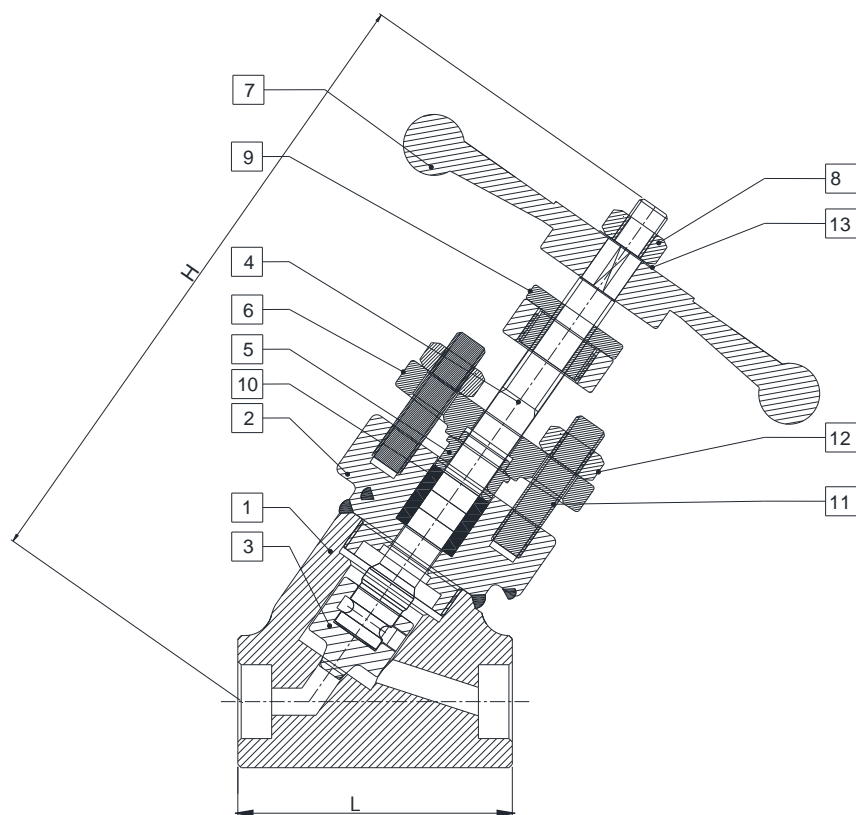

Sr.	Size	Class	L	H
1	15	1500	81.00	144.00
2	20	1500	100.00	162.00
3	25	1500	100.00	162.00
4	40	1500	140.00	222.00
5	50	1500	140.00	223.00

Sr.	Size	Class	L	H
1	15	2500	81.00	144.00
2	20	2500	100.00	168.00
3	25	2500	100.00	168.00
4	40	2500	140.00	228.00
5	50	2500	140.00	228.00

No.	PART NAME	MATERIAL	MATERIAL CODE
1	Body	Forged Steel	ASTM A105 /A182F11/F22
2	Bonnet	Forged Steel	ASTM A105 /A182F11/F22
3	Plug	S.S. + St.	ASTM A276-TP 410
4	Stem	Stainless Steel	ASTM A276 / A479-TP 410 / AISI 431
5	Gland Bush	Klinger Std.	ASTM A276-TP410
6	Gland Flange	Forged Steel	ASTM A105/A182F11/F22
7	Hand Wheel	M.I./C.S.	SG IRON / M.I.
8	Hand Wheel Nut	Carbon Steel	ASTM A 194 Gr.2H
9	Yoke Nut	SG Iron 400/12	SG Iron 400/12
10	Gland Packing	Graphite	Embedded -Die Formed Graphite
11	Stud	Alloy Steel	ASTM A 193 Gr.B7 / B16
12	Nut	Carbon Steel	ASTM A 194 Gr.2H/Gr. 4 / Gr. 7
13	Name Plate	Stainless Steel	Stainless Steel

Note: Electrical Actuator can be provided on request.



Model: UPSGTV with Hand Wheel (Standard Product)

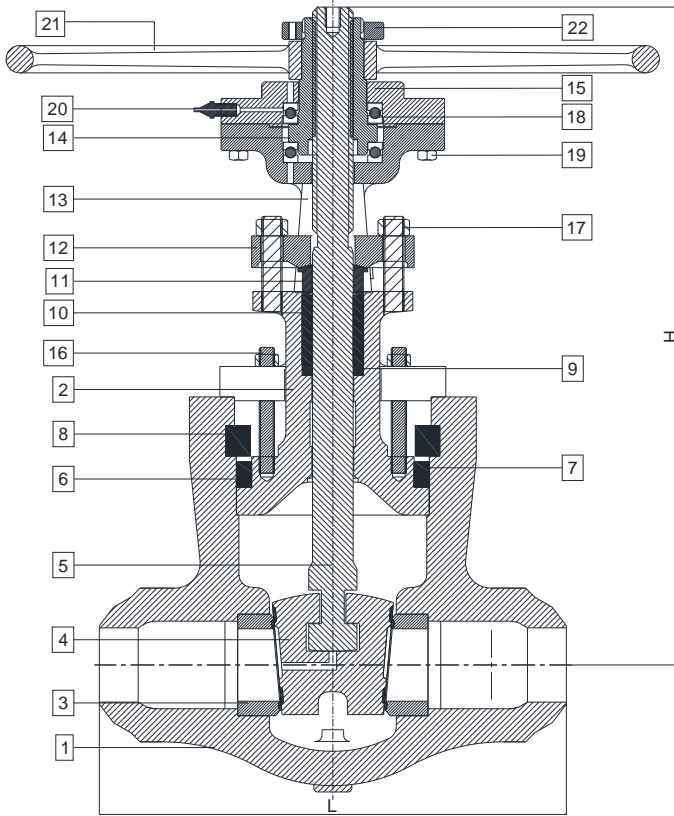

Sr. No	Size (NB)	Class	Length (L)	Height (H)
1	50	1500	216	434
2	80	1500	305	538
3	100	1500	406	569

Sr. No	Size (NB)	Class	Length (L)	Height (H)
1	50	2500	279	430
2	80	2500	368	518

Note:

- 1) Sizes 150 to 250 #1500 & 100 to 250 #2500, are Manual Gear Box operated.

Sr.	Item Description	MOC
1	Body	ASTM A216 Gr. WCB / ASTM A217 Gr. WC6/WC9
2	Bonnet	ASTM A216 Gr. WCB / ASTM A217 Gr. WC6/WC9
3	Seat	ASTM A216 Gr. WCB / ASTM A217 Gr. WC6/WC9
4	Wedge	ASTM A216 Gr. WCB / ASTM A217 Gr. WC6/WC9
5	Stem Stem (Back Seat HF)	ASTM A276 TP 410 / AISI 431
6	Pressure Seal Ring	Die Formed Graphite
7	Support Ring	ASTM A743 Gr. CA15
8	Segment Ring	ASTM A743 Gr. CA15
9	Anti Extrusion Ring	ASTM A276 TP 410
10	Gland Packing	Graphite - With Enconel Inhibitor
11	Gland Bush	ASTM A276 TP 410
12	Gland Flange	ASTM A216 Gr. WCB
13	Yoke	ASTM A216 Gr. WCB
14	Yoke Sleeve	SG Iron 400/12
15	Yoke Sleeve Retainer	ASTM A216 Gr. WCB
16	Yoke to Bonnet - Stud/Nut	ASTM A193 Gr. B7 / B16 / A194 Gr. 2H / Gr. 7
17	Gland Flange to Bonnet - Stud/Nut	ASTM A193 Gr. B7 / B16 / A194 Gr. 2H / Gr. 7
18	Thrust Bearing	Stainless Steel
19	Hex Bolts For YSR To Yoke	Gr. 8.8 Or Higher
20	Grease Nipple	Steel
21	Hand Wheel	ASTM A216 Gr. WCB
22	Hand Wheel Nut	Carbon Steel
23	Name Plate	Stainless Steel

Model: UPSGTV with Manual Gear Box (Standard Product)

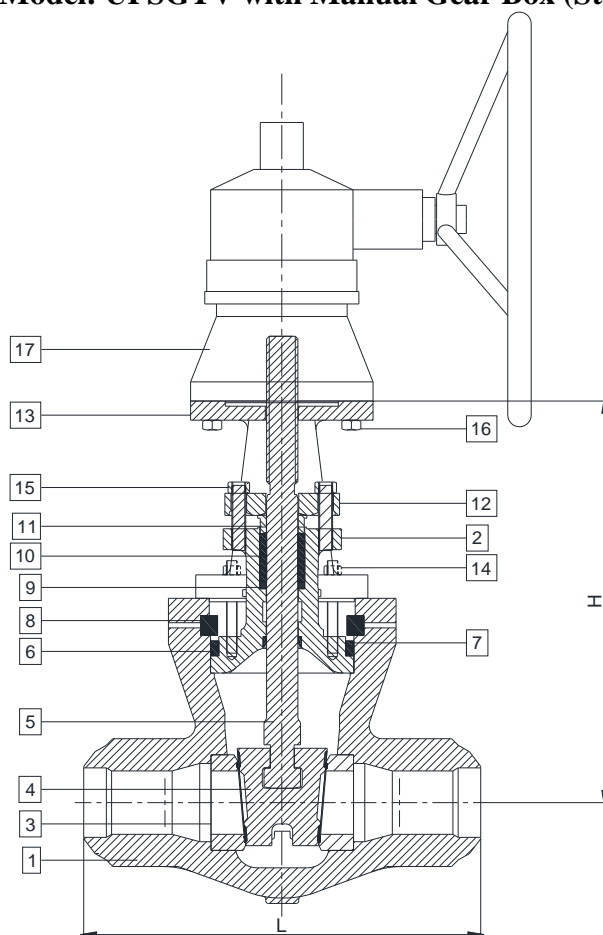

Sr. No	Size (NB)	Class	Length (L)	Height (H)
1	# 50	1500	216	351
2	# 80	1500	305	449
3	# 100	1500	406	473
4	150	1500	559	634
5	200	1500	711	860
6	250	1500	864	959

Sr. No	Size (NB)	Class	Length (L)	Height (H)
1	# 50	2500	279	342
2	# 80	2500	368	426
3	100	2500	457	462
4	150	2500	610	657
5	200	2500	762	867
6	250	2500	914	932

Note:

- 1) Electrical Actuator can be provided on request.
- 2) For # marked sizes, Manual Gear Box can be provided on request.

Sr.	Item Description	MOC
1	Body	ASTM A216 Gr. WCB / ASTM A217 Gr. WC6/WC9
2	Bonnet	ASTM A216 Gr. WCB / ASTM A217 Gr. WC6/WC9
3	Seat	ASTM A216 Gr. WCB / ASTM A217 Gr. WC6/WC9
4	Wedge	ASTM A216 Gr. WCB / ASTM A217 Gr. WC6/WC9
5	Stem (Back Seat HF)	ASTM A276 TP 410 / AISI 431
6	Pressure Seal Ring	Die Formed Graphite
7	Support Ring	ASTM A743 Gr. CA15
8	Segment Ring	ASTM A743 Gr. CA15
9	Anti Extrusion Ring	ASTM A276 TP 410
10	Gland Packing	Graphite - With Enconel Inhibitor
11	Gland Bush	ASTM A276 TP 410
12	Gland Flange	ASTM A216 Gr. WCB
13	Yoke	ASTM A216 Gr. WCB
14	Yoke to Bonnet – Stud/Nut	ASTM A193 Gr. B7 / B16 / A194 Gr. 2H / Gr. 7
15	Gland Flange to Yoke – Stud/Nut	ASTM A193 Gr. B7 / B16 / A194 Gr. 2H / Gr. 7
16	Allen Bolts for Yoke to Actuator	Gr. 8.8 or Higher
17	Actuator	As per requirement (Manual Gear Box / Ele. Actuator)
18	Cover Plate	Carbon Steel
19	Name Plate	Stainless Steel

UKL-DS-UHPV-R00-MARCH 2018

Model: UPSGLV with Hand Wheel (Standard Product)

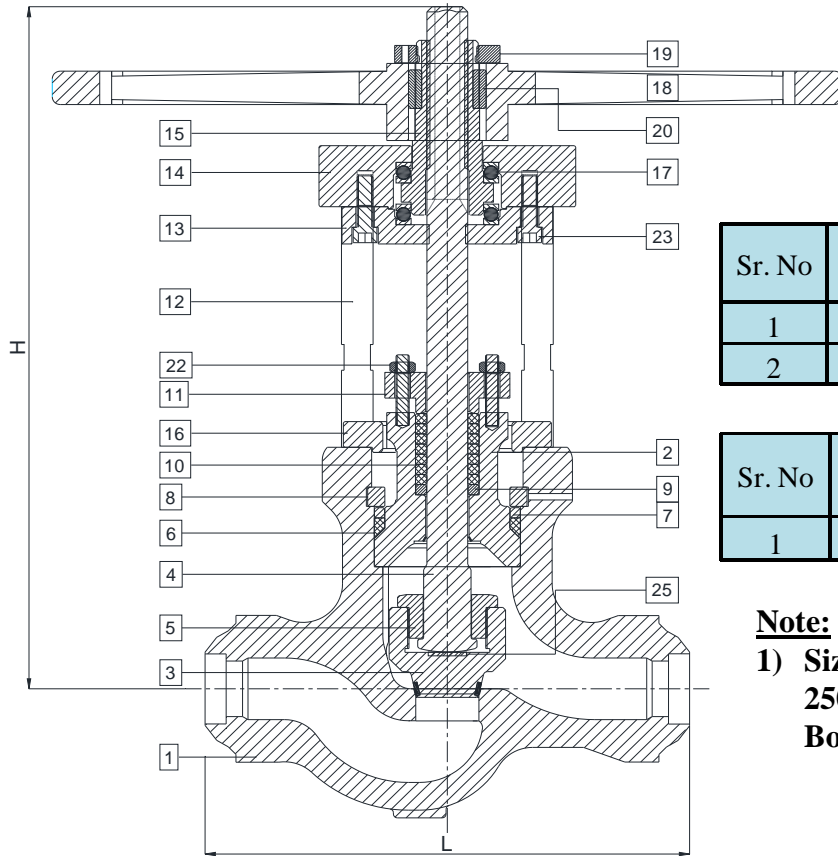

Sr. No	Size (NB)	Class	Length (L)	Height (H)
1	50	1500	368	531
2	80	1500	470	582

Sr. No	Size (NB)	Class	Length (L)	Height (H)
1	50	2500	451	560

Note:

- 1) Sizes 100 to 250 #1500 & 80 to 250 #2500, are Manual Gear Box operated.

Sr	Item Description	MOC
1	Body	ASTM A216 Gr. WCB / ASTM A217 Gr. WC6/WC9
2	Bonnet	ASTM A216 Gr. WCB / ASTM A217 Gr. WC6/WC9
3	Plug / Disc (Stellited)	ASTM A216 Gr. WCB / ASTM A217 Gr. WC6/WC9
4	Stem (Back Seat HF)	ASTM A276 TP 410 / AISI 431
5	Stem Nut	ASTM A216 Gr. WCB / ASTM A217 Gr. WC6/WC9
6	Pressure Seal Ring	Die Formed Graphite
7	Support Ring	ASTM A743 Gr. CA15
8	Segment Ring	ASTM A743 Gr. CA15
9	Anti Extrusion Ring	ASTM A276 TP 410
10	Gland Packing	Graphite - With Enconel Inhibitor
11	Gland Flange	ASTM A216 Gr. WCB
12	Support Stud	Carbon Steel
13	Bearing Cover Cum Retainer	ASTM A216 Gr. WCB
14	Top Plate	ASTM A216 Gr. WCB
15	Yoke Sleeve	ASTM A216 Gr. WCB
16	Cover Plate	ASTM A216 Gr. WCB
17	Thrust Bearing	STD
18	Hand Wheel	ASTM A216 Gr. WCB
19	Hand Wheel Nut	IS 2062 B
20	Hand Wheel Key	IS 2062 B
21	Stud/Nut Cover Plate to Body	ASTM A193 Gr. B7 / B16 / A194 Gr. 2H / Gr. 7
22	Stud/Nut Gland Flange to Bonnet	ASTM A193 Gr. B7 / B16 / A194 Gr. 2H / Gr. 7
23	Allen Bolt - BCCR To Top Plate	ASTM A193 Gr. B7 / B16 / A194 Gr. 2H / Gr. 7
24	Name Plate	Stainless Steel
25	Disc Thrust Plate	ASTM A276 TP 410

UKL-DS-UHPV-R00-MARCH 2018

Model: UPSGLV with Manual Gear Box (Standard Product)

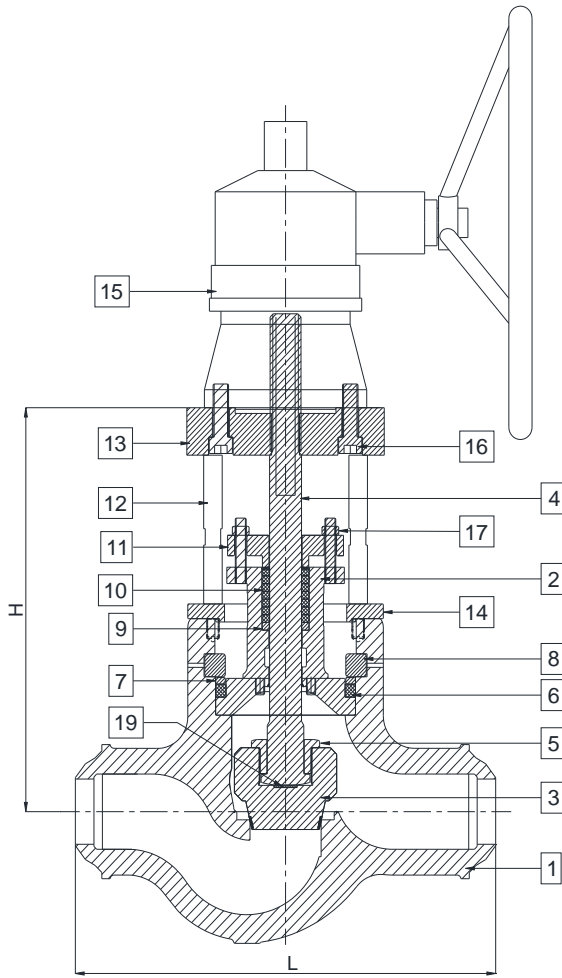

Sr. No	Size (NB)	Class	Length (L)	Height (H)
1	# 50	1500	368	423
2	# 80	1500	470	479
3	100	1500	544	494
4	150	1500	705	497
5	200	1500	832	595
6	250	1500	991	669

Sr. No	Size (NB)	Class	Length (L)	Height (H)
1	# 50	2500	451	462
2	80	2500	578	480
3	100	2500	673	532
4	150	2500	914	553
5	200	2500	1022	659
6	250	2500	1270	669

Note:

- 1) Electrical Actuator can be provided on request.
- 2) For # marked sizes , Manual Gear Box can be provided on request.

Sr.	Item Description	MOC
1	Body	ASTM A216 Gr. WCB / ASTM A217 Gr. WC6/WC9
2	Bonnet	ASTM A216 Gr. WCB / ASTM A217 Gr. WC6/WC9
3	Plug / Disc (Stellited)	ASTM A216 Gr. WCB / ASTM A217 Gr. WC6/WC9
4	Stem (Back Seat HF)	ASTM A276 TP 410 / AISI 431
5	Stem Nut	ASTM A216 Gr. WCB / ASTM A217 Gr. WC6/WC9
6	Pressure Seal Ring	Die Formed Graphite
7	Support Ring	ASTM A743 Gr. CA15
8	Segment Ring	ASTM A743 Gr. CA15
9	Anti Extrusion Ring	ASTM A276 TP 410
10	Gland Packing	Graphite - With Enconel Inhibitor
11	Gland Flange	ASTM A216 Gr. WCB
12	Support Stud	Carbon Steel
13	Top Plate	ASTM A216 Gr. WCB
14	Cover Plate	ASTM A216 Gr. WCB
15	Actuator	As per requirement (Manual Gear Box / Ele. Actuator)
16	Allen Bolts for Yoke to Actuator	Gr. 8.8 or Higher
17	Stud/Nut Gland Flange to Bonnet	ASTM A193 Gr. B7 / B16 / A194 Gr. 2H / Gr. 7
18	Stud/Nut Cover Plate to Body	ASTM A193 Gr. B7 / B16 / A194 Gr. 2H / Gr. 7
19	Disc Thrust Plate	ASTM A276 TP 410
20	Name Plate	Stainless Steel



Electrical Actuator Details:



- 1) EPAC Electrical Actuator in “Norm” Version (without integral Starter) suitable for "ON-OFF“ duty / Regulation duty.
- 2) 2 nos. Limit switches of 2NO+2NC contacts and 2 nos. Torque switches of 2NO+2NC contacts.
- 3) Current rating 5A/0.4A at 240V, AC/DC. Enclosure of switches IP66
- 4) Motor suitable for 415V, 50Hz, 3 phase AC power supply.
- 5) Insulation Class - F
- 6) Protection Class - IP67 / IP 65
- 7) Hand wheel for emergency manual operation which disengages as soon as motor operation is resumed.
- 8) Continuous dial type mechanical position indicator for local indication.
- 9) Suitable for an ambient temperature of -20°C to +80°C.
- 10) All switches and motor connections are brought to a common terminal box for customer connections with terminals for power and control.

UKL High Pressure Valve End Connection Details:

Socket Weld details and table as per ASME B 16.11

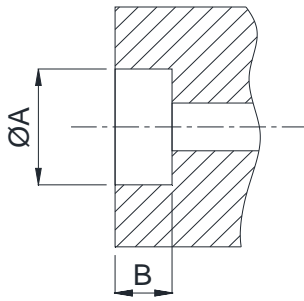

Size NB		Socket Bore ØA (mm)	Socket Depth B (mm) min.
Inch	mm		
1/2"	15	21.80	10.00
3/4"	20	27.20	13.00
1"	25	33.90	13.00
1 1/2"	40	48.80	13.00
2"	50	61.20	16.00

Butt-weld Ends as per ASME B 16.25, (Welding end detail for joint without backing ring)

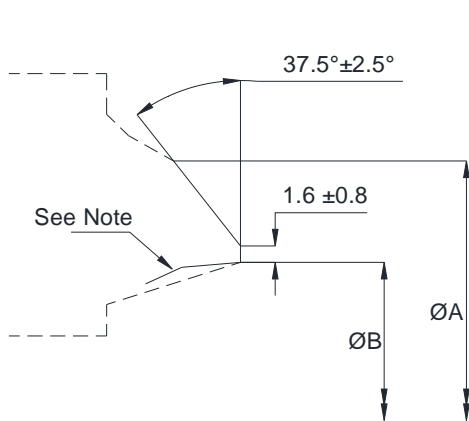

For wall thickness less than 22 mm (0.88")

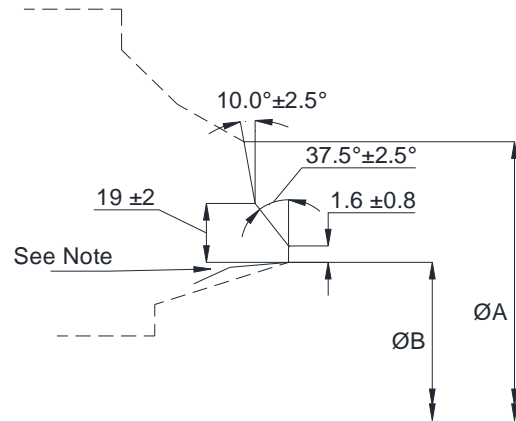

For wall thickness greater than 22 mm (0.88")

Size NB		ØA (mm)	ØB (mm)		
Inch	mm		SCH. 80	SCH. 160	SCH. XXS
1/2"	15	23.00	13.84	11.74	6.30
3/4"	20	28.00	18.88	15.50	11.10
1"	25	35.00	24.30	20.60	14.60
1 1/2"	40	50.00	38.14	34.02	27.90
2"	50	62.00	49.22	42.90	38.10
3"	80	91.00	73.50	66.50	58.50
4"	100	117.00	97.00	87.50	80.00
6"	150	172.00	146.50	132.00	124.50
8"	200	223.00	193.50	173.00	174.50
10"	250	278.00	243.00	216.00	--

Note:

Internal surface may be reformed or machined for dimensions B at root face. Contour within the envelope is manufacturer's option.

Body/Bonnet Materials

Cast Steel Gate and Globe Valves are offered in a variety of body and bonnet materials to suit different requirements. These materials include Carbon Steel, Alloy Steels and stainless steels.

Other materials of construction can be provided on request.

Material Code	Material Specification	Working Temp. Range
ASTM A 216 Gr. WCB / ASTM A 105	C-Si (Carbon Steel)	-29°C to 425°C (-20°F to 800°F)
ASTM A 217 Gr. WC6 / ASTM A 182 F11 CL.2	1¼ Cr- ½Mo (Alloy Steel)	-29°C to 593°C (-20°F to 1100°F)
ASTM A 217 Gr. WC9 / ASTM A 182 F22 CL.3	2¼ Cr- 1Mo (Alloy Steel)	-29°C to 593°C (-20°F to 1100°F)
ASTM A 352 Gr. LCC / ASTM A 352 Gr. LCB	C-Si (Carbon Steel) (Low Temp. Steel)	-46°C to 343°C (-50°F to 650°F)
ASTM A 351 Gr. CF8 / ASTM A 182 F304	18Cr-8Ni (Stainless Steel) (Austenitic)	-196°C to 538°C (-320°F to 1200°F)
ASTM A 351 Gr. CF8M / ASTM A 182 F316	16Cr-12Ni-2MO (Stainless Steel)	-196°C to 538°C (-320°F to 1200°F)

How to order:

Example: Ordering Gate Valve of 15 NB Class1500 for steam application & MOC of valve F22.

Type: UHPGTV

MOC: ASTM A 182 F22 CL.3

Size: 15 NB

Pressure Class: 1500

End Connection: Socket Weld End / Butt Weld

Pipe Schedule: SCH. 80 / 160 / XXS.

Operating Pressure (in Bar / Kg/cm²):

Operating Temperature (in °C):

Fluid to be handled (Media):

Accessories:

In case operation is using Manual Gear Box / Electrical Actuator, Design Pressure (in Bar / Kg/cm²) & Design Temperature (in °C) is also required.

How to Store:

UKL High Pressure Valves and the respective spares should be stored only in enclosed dry rooms in a non-aggressive atmosphere.

Fully assembled UHPV must be stored as supplied by UNI KLINGER.

Spare parts must be handled with care and should be stored in their original packing.

Other Products : 

Cast / Forged Steel Piston Valves, Bellow Seal Valves, High Pressure valves (Gate/Globe) , Strainers – “Y” Type, Flash Vessel, Steam Traps (Thermodynamic, Thermostatic, Ball Float Traps, Inverted Bucket), Pressure Reducing Station, Condensate Recovery Products, Level Gauges (Reflex, Transparent, Bicolor), Sight Glass, Hot Water Generation System, Safety and Relief Valves.

FSD Products : Compressed Asbestos / Non Asbestos Fiber Sheeting / Cut Gaskets, Spiral Wound Gaskets.

In view of technical progress designs and dimensions are subject to change without notice.



UNI KLINGER LIMITED

A joint venture of the Neterwala group of companies and KLINGER AG, Switzerland.



HARSH ENGINEERING SALES & SERVICE PVT. LTD

Only Authorized Dealers for UNI KLINGER products, Telangana

Add: 2-3-692/22/13 Lal Bagh, Zinda Tillismath Road, Ganga Nagar, Amberpet, Hyderabad - 500013
Tel: +91-40-2740 3329 | Website: harsh-engineering.com | E-mail: sales@harsh-engineering.com